

## Boosting Drive Motor and Related Circuits:

2 bridge rectifiers will create a voltage doubler circuit

### Stepper Motor Selection & Lead Identification

On the side of most stepper motors technical specifications will be labelled. The important parameters are the maximum voltage ( $V_{max}$ ), the current per phase ( $A/Ph$ ), and the number of steps or degrees per step. A 3.6 degree stepper motor for example has  $360/3.6 = 100$  steps, a 1.8 degree stepper motor has  $360/1.8 = 200$  steps. A typical stepper motor based wind turbine generator will operate at around 200 rotation per minute(RPM).A motor rated at 50 volts for example could be used to charge a 12 volt battery at low speed, whereas a 15 volt stepper motor could only charge a 12 volt battery when up at its full speed!!In principle,the higher the number of steps in the motor, the lower the RPM required to generate a decent voltage. So, if you had to choose between two motors with identical voltage and current characteristics then you should choose the motor with maximum steps.

Most stepper motors have 6 leads, however there are motors with 4, 5, or 8 leads also. Each of the four coils is made up of one length of wire with two ends. One end is called live and the other end is called common. In a five-lead stepper motor all four commons are joined together, in a six-lead stepper motor two pairs of common wires are joined together. But in an eight-lead stepper motor none of the four common wires are joined together.

For lead identification,systematically use a good quality digital multimeter(DMM) to measure the resistance between different pairs of wires. All four coils will have near identical resistances . If they did not the motor would not function properly.If the pair of wires being measured are both live, the resistance measured will be double that measured if one of the wires is a common. When you have identified the common wires, be sure to label them.Having identified the leads emerging from the stepper motor, it is now very easy to rectify the multi phase alternating current output into more useful direct current.

### Charge Controllers

A charge controller is crucial for a wind turbine used to charge a battery bank.A typical wind turbine charge controller constantly monitors the battery voltage. If the voltage reaches a set value, ie the float voltage , then the controller turns on a shunt(dump) load which dissipates excess power to prevent it from overcharging the batteries.When the battery voltage is measured to have fallen back below a set threshold ,typically 0.2V-0.5V below the float voltage, the shunt load will be switched off and battery charging will start again. An ordinary battery charge controller cannot be used with a wind turbine generator since the wind turbine controller must ensure that the wind turbine is constantly under load to prevent it from spinning out of control and being damaged in strong winds by overspeed.

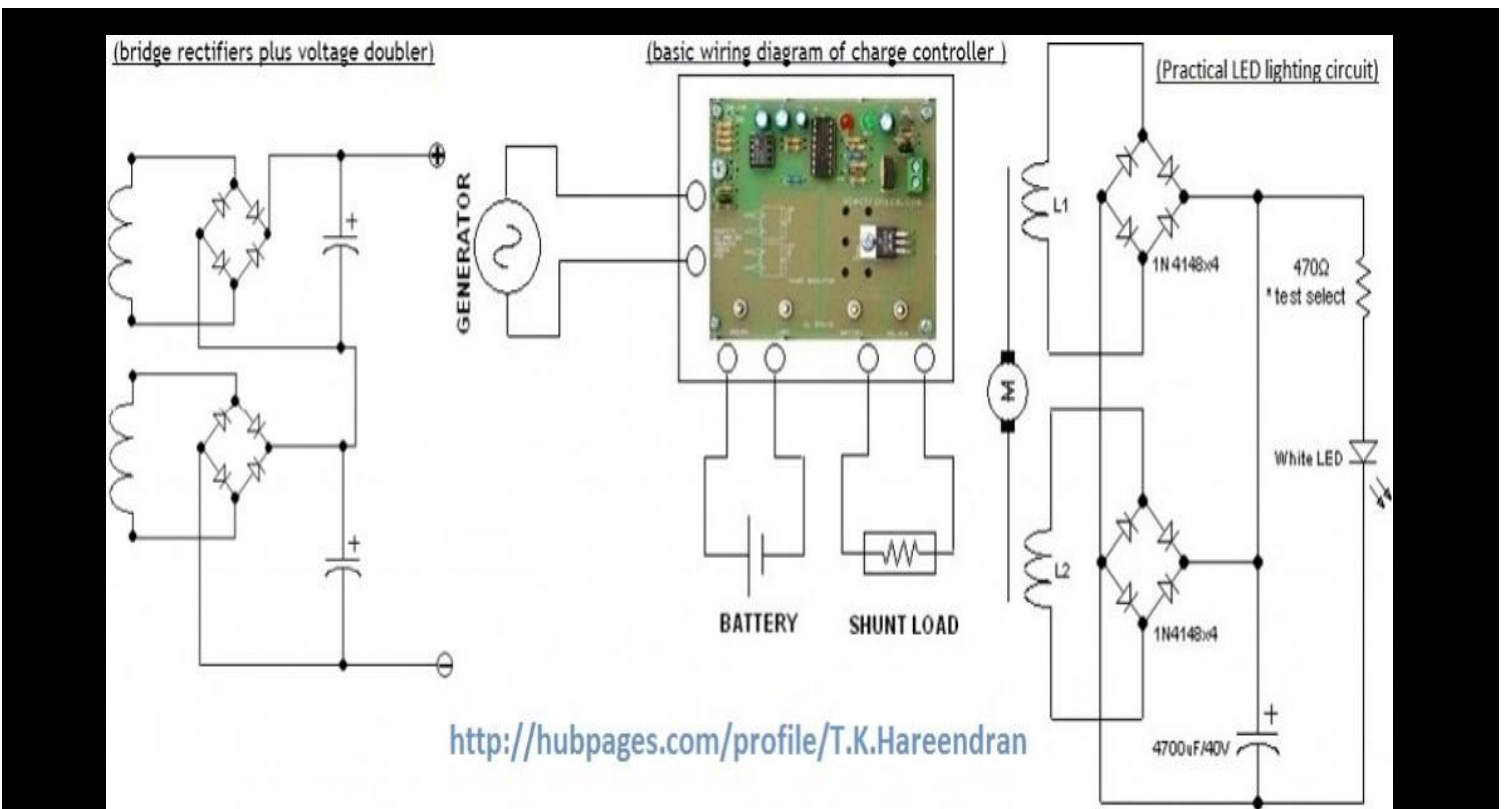

The stepper motor generator

This size 34 -14 v stepper motor

Stepper motors are multi-pole modern they have four phases As with a DC permanent magnet makes it work backwards, causing the windings. However, the current approaches a coil and then minus four phases at 90 degree intervals the next one has reached means the output can be rectified with hardly any gaps, but it means It's quite easy to figure out which resistance meter. The six wire so the six wires can immediately three. Each group will have some connection to any of the other the common and the other two are which will give out oppositely In terms of resistance, the reading be half the reading across the two on one set, you can use the same other one. All four windings will resistance.

The simplest way to wire it up is to terminal and then connect each of diode (1n4001) to the plus output.

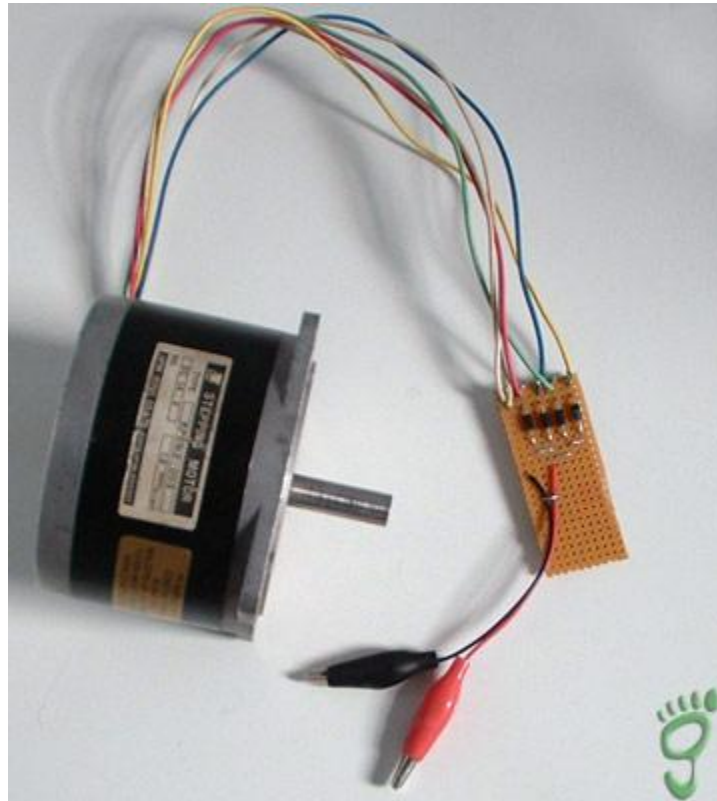

was bought on eBay for £25.

alternators, but being more while the Dynohub has only one. motor, turning the motor's shaft pulses of current to come out of is AC, going plus as a magnet pole as it moves away. Usually there are so when one comes down to zero, maximum. This is a benefit as it to produce much smoother DC they have more wires coming out. way around they are using a stepper is really two motors in one, be separated into two groups of connection to each other, but no group. In each group, one wire is the opposite ends of a winding phased AC. from the common to either end will ends. Having found the common process to find the common in the have almost exactly the same

link the two commons to the minus the four live phases through a

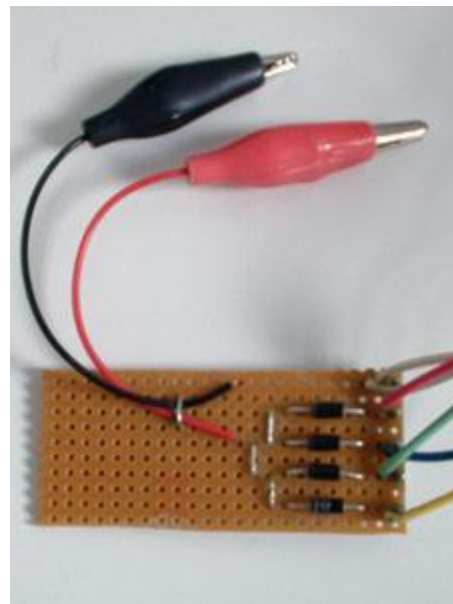
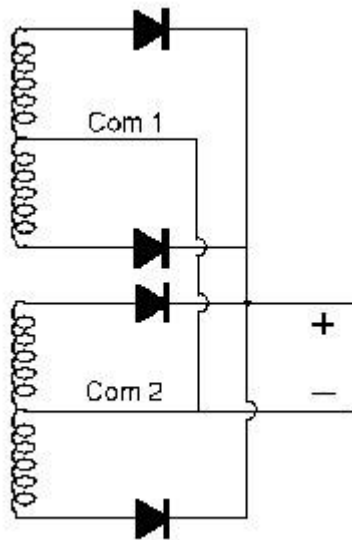

I found the simplest, and cheapest method of regulating the voltage was to buy a car cigarette voltage converter, the 1 amp version was on sale at maplin for £6.99. It had the added advantage of a choice of output voltages, between 1.5v to 12v although the unit might get a bit hot when operated at lower voltages.



I achieved some reasonable results with this stepper, getting 12volts at approximately 200rpm, and then rising to about 60 volts with increasing the shafts speed, using a cordless

drill to power the motors shaft. The current limited itself to 0.32 Amps. Therefore using ohms law  $W=I \times V$

$$12v \times 0.32A = 3.84 \text{ watts @ 200 rpm.}$$

$$60v \times 0.32A = 19.2 \text{ watts @ 1000 rpm.}$$

I need to find a way of regulating the voltage to approx 14 volts, for battery charging - and possibly increase the current, ideas welcomed.

Visitor Miles Hodkinson commented: As the voltage increases into the battery bank the current will increase proportionally and the voltage will stay reasonably constant.

With such a small generator I doubt a large leisure battery would ever be troubled (county batteries do a 110ah for £55). You could also use a solar charge controller.

---

A wind turbine can charge a pair of AA NiCad batteries in about 10 hours

am trying to charge a battery by spinning motors but the obvious question is when i connect them the battery will give energy to the motors how do i stop the battery from giving power but to take power from the motor and charge?

Simplest is a single diode to allow current to only go from the motor to the battery.. You just need to choose diodes that fits the output (V&A).

---

### **Charging a Battery**

The motor must be able to produce enough voltage to charge the battery. For example if the rated voltage of the battery is 5 V then the motor must be able to produce at least 5 V. It also must be able to generate enough current so that the time required to charge the battery is lowered. The larger the amperage the shorter time will be required to recharge the battery. Rechargeable battery capacity is rated in mAh (milliampere-hours). The total capacity of a battery is defined as "C", that is it can supply C mA for 1 hour, or 2C for 30 minutes etc.<sup>[5]</sup>The rate of charge is determined by how much electrical current is allowed into the battery by the battery recharger.<sup>[6]</sup>The charge current depends upon the technology and capacity of the battery being charged.<sup>[3]</sup> As a general rule, to arrive at an appropriate charge rate, the capacity of the batter should be divided by 10 (this is called the C/10 rate). There are however charge rates as high as C/3, but this charge rate will only be maintained for a short period of time.<sup>[7]</sup> Therefore the fastest amount of time that a battery can be recharged is 3 hours but the recommended charge rate should be used. To find the recommended charge rate of the battery one should contact the battery manufacturer.

A battery rated at 150 mAh (the one used in this design) can theoretically sustain a 15 mA discharge current for 10 hours (150 mAh/ 15 mA). Some LEDs have a maximum rated amperage of 15 mA.

However it is very important to note that the battery is not overcharged, nor should it be charged at a rate that the battery cannot handle. If the battery is overcharged it may explode. It is important to understand all of the parameters involved in charging a battery before constructing a battery charger. It is also important to note that no battery will last forever as they wear out and will eventually need to be replaced<sup>[7]</sup>, however rechargeable batteries are a great way to reduce cost and waste.<sup>[6]</sup> One downside to batteries is that when they do need to be replaced they contain toxic materials and should be disposed of properly.<sup>[7]</sup> To avoid shortening the life of a battery considerably, the battery should not be completely discharged before being recharged.<sup>[6]</sup>

**Performance and Discussion**

The final prototype works although there are many improvements to be made on the design. The most notable design change would be to have a better system to spin the rim, ideally one that was not human powered. The design consists of a wheel that is rotated by hand that is connected to a DC motor. The motor is connected to the battery and when the wheel spins it provides electricity to the charge battery. The battery chosen was a 4.8V 150mAh battery that was turned into a 3.6V 150mAh battery. This means the fastest possible charge rate is 50mAh based on the C/3 rate or lower depending on what charge rate is chosen. To be safe the battery will be aimed to be charged at C/5 (which means it would take 5 hours to charge this battery). Some testing done on the prototype was done and the data shown in table 1 shows the results. The amount of current and voltage through the circuit is proportional to the rotating speed of the rim. The motor easily puts out the required amount of voltage needed to charge the battery and exceeds the acceptable charge rate current which is why a resistor must be incorporated into the electrical circuit design.

<i>Table 1: Test Results</i>		
Speed of the Rim	Reading Amps (mA)	Reading Volts (V)
Maximum achieved	280	8.35
Tolerable, about 2 rim revolutions per second	110	3.60
Slow, about 1 rim revolutions per second	50	1.54

The most interesting design change would be to have the wheel spin by some other means than human power. If the design could incorporate a waterwheel or small wind turbine blades to spin the rotor the overall effectiveness of the machine greatly increases. After doing some testing it was found that when the wheel is moving rather slowly it produces enough voltage to charge a 1.5V battery at 50mA. This means that one cell of the battery used in this prototype (1.2V) would take only 3 hours to charge permitting it could charge at a rate of 50mAh, or it could charge a larger capacity battery for example a 500mAh battery in 10 hours of spinning. This slow speed could possibly be obtained by turning the rim of the bicycle into a waterwheel design. This would greatly improve the overall effectiveness of the system in that someone would not have to waste time turning the rim and could focus on other tasks. A more efficient human powered design would be a pedal powered design. It would allow for a significant increase in power to be input into the system and therefore an increase in the amount of electricity that can be produced.

Rather than using a voltmeter to regulate the voltage in the system, a simple voltage regulator chip could be implemented. Since the project is intended to be a practical technology this may not be a viable design change. And if there is a more constant source of spinning (such as a water wheel) one could regulate the voltage by the rate of speed the rim turns and the gear ratio from the rim to the motor. More voltage and current could be produced if there was a much larger section of rim the belt went around. The larger in diameter the rim/belt connection is the faster the motor spins for every revolution of the wheel.

**[edit] Parts List and Cost**

<i>Table 2: Parts List</i>		
Part	Required Units	Total Cost (CAD)
DC Motor (capable of producing enough V to charge battery)	1	\$0.00

Rubber Belt (capable of being fixed to rotor)	1	\$0.00
Old Bicycle Rim	1	\$0.00
Nails	~12	#
Scrap Wood	(see construction section)	#
NiMH Battery (4.8 V, 150 mAh)	1	\$13.95 <sup>[8]</sup>
Copper Wire	6 inches to a Foot	#
Diode	1	#
Resistor (120 Ohm)	1	#
Lengths of wire	-	\$0.00
Alligator clips	2	\$3.10 <sup>[8]</sup>
Electrical Tape	~1 foot	\$2.79 per roll <sup>[9]</sup>

Note:

The DC motor and the corresponding rubber belt were removed from an EPSON Stylus CX3810 printer that no longer functioned properly. There were 3 motors in the printer (two DC motors and one stepper motor). The motor that ran the cartridge feeder was used as it has the gear connection to a rubber belt already attached. In other words it was the motor that was meant to be connected to the rubber belt. The lengths of wire were also extracted from the printer. The bicycle rim was found in a scrap yard; the bearings in the rim were still in good condition and allowed the rim to spin freely. The rim does not have to be in the best condition, as long as it can spin freely on the axle. There is no specific lengths/type of wood that need to be used, as long as there is enough material to allow the rim to be properly mounted and rotate freely as discussed in the *mounting the rim section* (step 1). Because all of the above materials were salvaged the cost of the project was dramatically reduced. The most significant costs of the project will be due to the battery and the motor. Unfortunately the DC motor from the printer was unable to be identified. To choose the right motor one should hook up the leads of the motor a voltmeter and manually spin the rotor. The voltage should be able to exceed the rated voltage of the battery that is planned to be used.

#### Wiring the charger

The circuit diagram for this battery recharger is shown in figure 5.

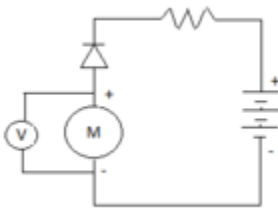

Figure 5: Circuit Diagram from Mechanical Recharger

Firstly the proper current direction must be established. The red wire was chosen to be positive. Hook the positive lead of the voltmeter up to the red (positive) wire and the other lead to the black wire and spin the rim to determine which direction gives a positive voltage. Mark this on the support as shown in figure 6.

#### How to Generate Static Electricity to Charge a Battery

X Rachel Murdock Rachel Murdock published her first article in "The Asheville Citizen Times" in 1982. Her work has been published in the "American Fork Citizen" and "Cincinnati Enquirer" as well as on corporate websites and in other online publications. She earned a Bachelor of Arts in journalism at Brigham Young University and a Master of Arts in mass communication at Miami University of Ohio.

By Rachel Murdock, eHow Contributor Charge a 12-volt battery with static electricity. Under most conditions, static electricity of the type that shocks your fingers when you touch a doorknob cannot charge a battery. To have that happen, you need to convert the high-voltage and low-current static electricity into low-voltage, moderate-current electricity for a long period of time. This can be done, but should not be attempted by an amateur. Ham radio operators may have long wire antennas already mounted in the air to collect static electricity.

#### You'll Need

- Long, insulated wire
  - Spark plug
  - Automotive 12-volt coil
  - 20kv capacitor
  - Ground rod
  - Small piece of insulated wire
  - 12-volt, deep cycle storage battery such as a marine battery
- Show (4) More Instructions

1

Hang a long piece of insulated wire, preferably coaxial cable. The wire can be treated by heating it to approximately 100 degrees C. The heating of the wire will allow it to absorb more electrons. Hang between 400 and 1000 feet of wire.

2  
Connect the bottom connector of the automotive coil to the positive side of the marine battery.

Drive the grounding rod into the ground. Strip the ends of the small piece of insulated wire and connect the negative terminal of the battery to the ground rod.

4  
Connect the spark plug to the bottom of the long wire hanging in the air. Hang the "sparking" end of the plug about 2 mm above the ignition coil.

5  
Attach the second shorter wire to the ground rod, then to the capacitor, then back to the long, suspended wire just above the spark plug.

#### Tips & Warnings

Bad weather will increase the amount of static electricity collected by this system.

In emergency situations, have two or more batteries to rotate. **The system made with a 200-foot wire should completely charge a 12-volt battery in two to three days** -- the longer the wire, the shorter the time it will take to charge the battery.

---

To connect the coil to the battery, we will use the bottom connector of the automotive coil that is normally connected to the points in your car. This will now be connected to the positive side of your emergency battery. The negative post of the battery is simply hooked up to a good earth ground.

It is a well-known fact that enormous charges can build up on long wire antennas and the longer the wire the more charge that it will build. Most hams think of this as a disadvantage. I would like to further explore the possibility of how we can turn this into a distinct advantage for both emergency backup power and wilderness radio energy requirements.

I know that our antennas are supposed to intercept the vertical DC current coming down from the sky. This typically represents a high voltage at a few micro amps (the higher up your antenna is located off the ground, the higher the voltage values on your antenna.)

We can further validate this information by trying this little experiment that only a ham operator would actually be caught doing:

First let's hook up an NE-2 bulb from the antenna to ground, and then watch the bulb in a dark room. It should start blinking repeatedly. Once you see the bulb flashing, try hooking a few more NE-2 bulbs in series to determine how much power your antenna wire can produce. For those that may not be sure what an NE-2 bulb might look like, here is a photo:



You can "approximate" the voltage available by adding more NE-2 light bulbs into the circuit chain until they won't flash anymore.

In this experiment, we can assume that each bulb adds about 100V to the trigger voltage. If you can persuade a series chain of 10 bulbs to blink, then your antenna is probably putting out at least several hundred volts, maybe even a 1000V!

Let's start this project by choosing a good marine battery. Marine batteries will typically hold a charge longer than regular car batteries. Regular car batteries can lose a charge just sitting around at a rate of almost 2 amps a day... This means precious backup power will be literally lost into thin air! Our objective in this situation is to store as much emergency backup power in reserve as possible, for the longest period of time possible.

Generally speaking, batteries that are rated in “reserve minutes” will typically outlast batteries that are rated in “crank amps.”

Next you will need a working spark plug. I prefer the V groove type, but any old spark plug will work just fine. Start by hooking up the spark plug tip to the end of your antenna wire (antenna wire described later) and then run the ground end of the spark plug (where the threads are) into the top cap of a 12-volt automotive coil. Any old salvaged working coil will do. (Of course, except for the one your wife currently uses in her car.)

It is important to choose only insulated antenna wire for this project, as this will work best. The wire should be completely insulated from end to end with no breaks or soldered connections anywhere in-between. It doesn't seem to make any difference whether you lay it out in a straight line, is a looped antenna configuration, or if it weaves back and forth. Length is the key, not its footprint size.

Old discarded phone line, old cable TV coax, practically any wire that is insulated and long will provide satisfactory results provided that you don't tear the neighbor's cable TV wire out of his lawn, you shouldn't have any problems using any type of insulated wire for this project.

To connect the coil to the battery, we will use the bottom connector of the automotive coil that is normally connected to the points in your car. This will now be connected to the positive side of your emergency battery. The negative post of the battery is simply hooked up to a good earth ground.

You can make this work in field, wilderness or portable radio operations by driving a temporary ground rod into the earth and then connect the ground directly to the negative post on your battery.

Next we install a 1 to 3 KV capacitor. The capacitor value will work best if it is around a few pico-farads like those typically found in the horizontal section of a television chassis. The capacitor is then connected from ground back to the wire where the top of the spark plug is connected to the antenna.

Nothing should be touching ground except the ground post of the battery. Approx. 200 feet of insulated wire will completely charge a 12 volt deep cycle every 2 or 3 days! A thousand feet of wire will do it a lot quicker but the voltages will approach lethal levels.

This works as a charging system because the long antenna wire acts like a capacitor building an electric charge on the antenna wire. When a few thousand volts are reached, it will be discharge by “sparking” across the spark plug. The spark plug then delivers the electric charge to the coil, which in turn “downconverts” it to a few hundred volts. The electricity is then injected into the battery from the coil. The coil works by “pulsing” the charge into the battery at regular discharge intervals.

The weather controls how much static electricity is in the air at any given time during the course of the day or night. This electricity is then made available for charging our battery.

The real advantage of this particular charging system during an emergency situation is that the worst the weather gets, the more electricity you will have at your disposal for charging your battery.

When conditions such as wind and super cold air are frequently persistent, you will be able to weld the fillings in your teeth together! ...Be careful!

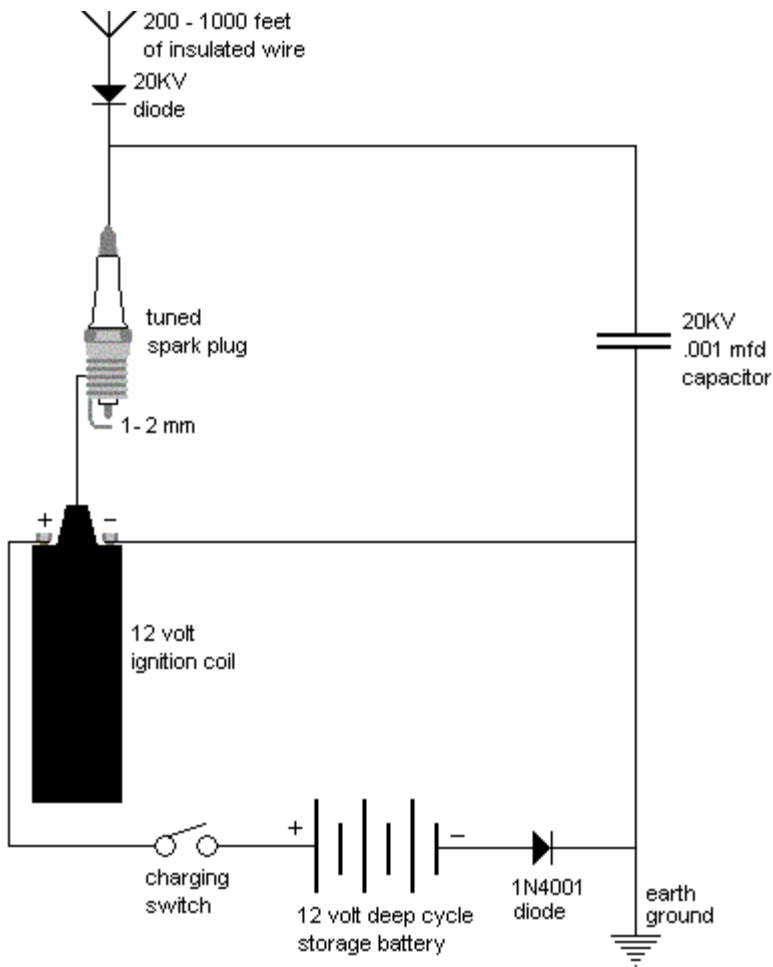

The higher you get the insulated wire of the ground, the better it will work in capturing DC current from the air for this highly effective, but low cost emergency battery charging system.

Created a small solar charged battery powered electric fence charger. Used a 3.3 volt Sparkfun Arduino Pro mini with a FET soldered direct to pin 3 and ground running the blink led sketch. Solar panel keeps the 6 ah Lipo battery charged

---

Pizeos" ... the type often used to light propane bbq grills.

Gift Card Speaker has pizeo electric speakers

Epsom Stepper Motors generate 4 volts



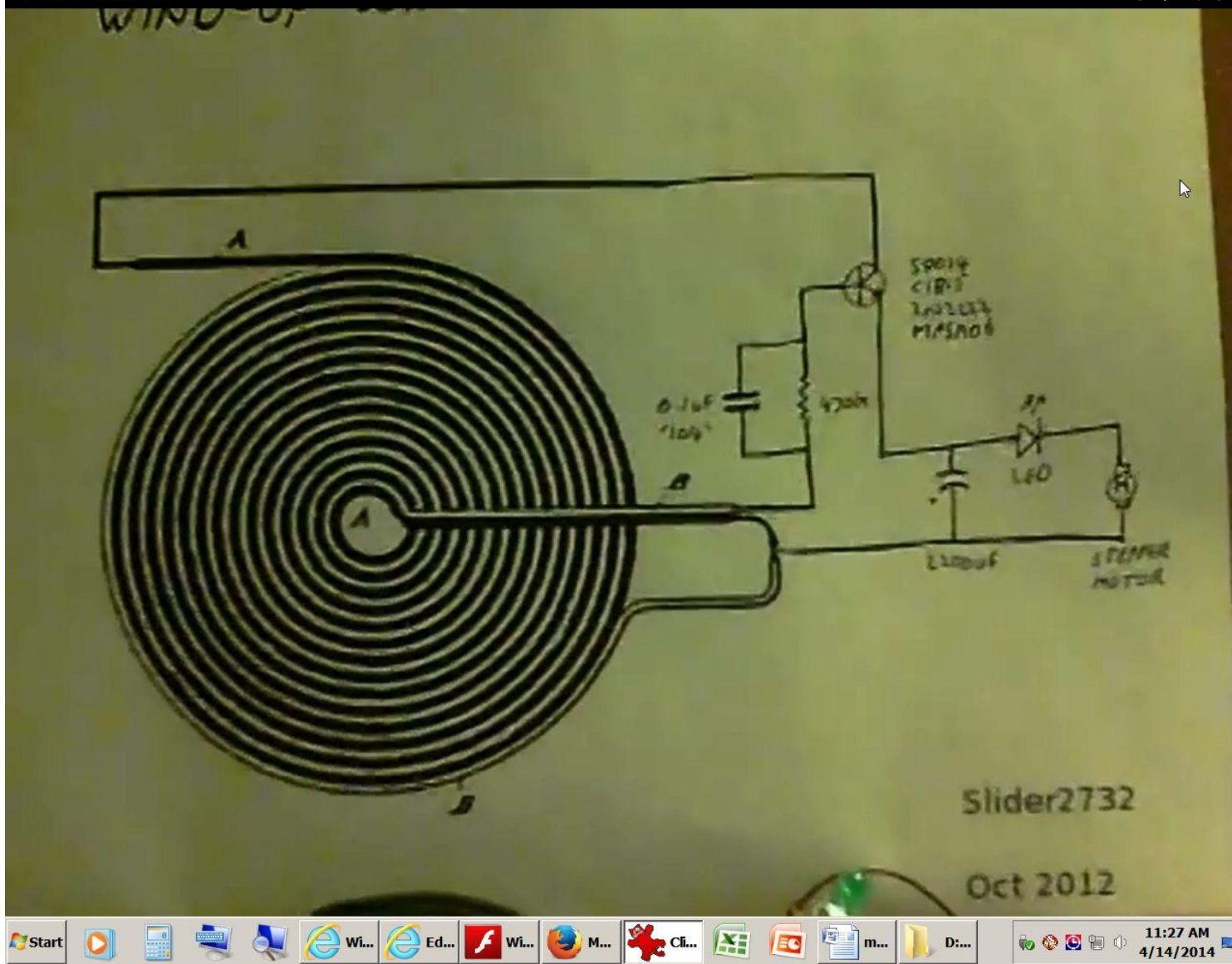

Above from video: <https://www.youtube.com/watch?v=aNuhnZ4oNSk>  
 2.200 uf capacitor

Text from above video:

After struggling with dodgy meter readings for good solid power input figures within previous experiments, I decided to ditch the use of batteries altogether !

A stepper motor is used, 2 wires of which run to an LED to show the power delivery and rectify the output, then across a capacitor to store the energy. The capacitor connects to the very simple wireless circuit.

The circuit uses a 'tank' section, to cut down on the power drawn from the capacitor and will deliver many minutes of output from about 20 wind up turns of the motor shaft.

The motor shaft can be turned in either direction, or even rocked left and right and still work. Ideally a turning handle would be fitted to the motor shaft.

In case of difficulty reading the schematic. The pancake is wound as a conventional bifilar Tesla pancake. The wire is from an old modem cable/telephone 2 core wire.

Receiving coils can be single filar, and of a different size to the transmitting coil.

Capacitor can be anything, the bigger the better and the longer the circuit will run, but the longer it may take to charge up.

Transistor can be any good high hFE signal transistor, such as the S9014, C1815, 2N2222 or MPSA06.

Resistor here is a 470K, higher resistance will increase the run time, but lower the output brightness, same for the 0.1uF (104 marked) ceramic capacitor.

The stepper motors seen came from old PC printers.

All components used are salvaged parts from junker stuff :)

The battery charging can take a while, but does work, in common with Joule Thief battery charging methods.

Other uses can include transmitting wind generator energy through window panes (a Kyle Carrington classic idea from posts in another video), 1 wire applications and, with a more refined circuit emergency cellphone charging...to name a few.

The image below boosts voltage for wind driven circuits:

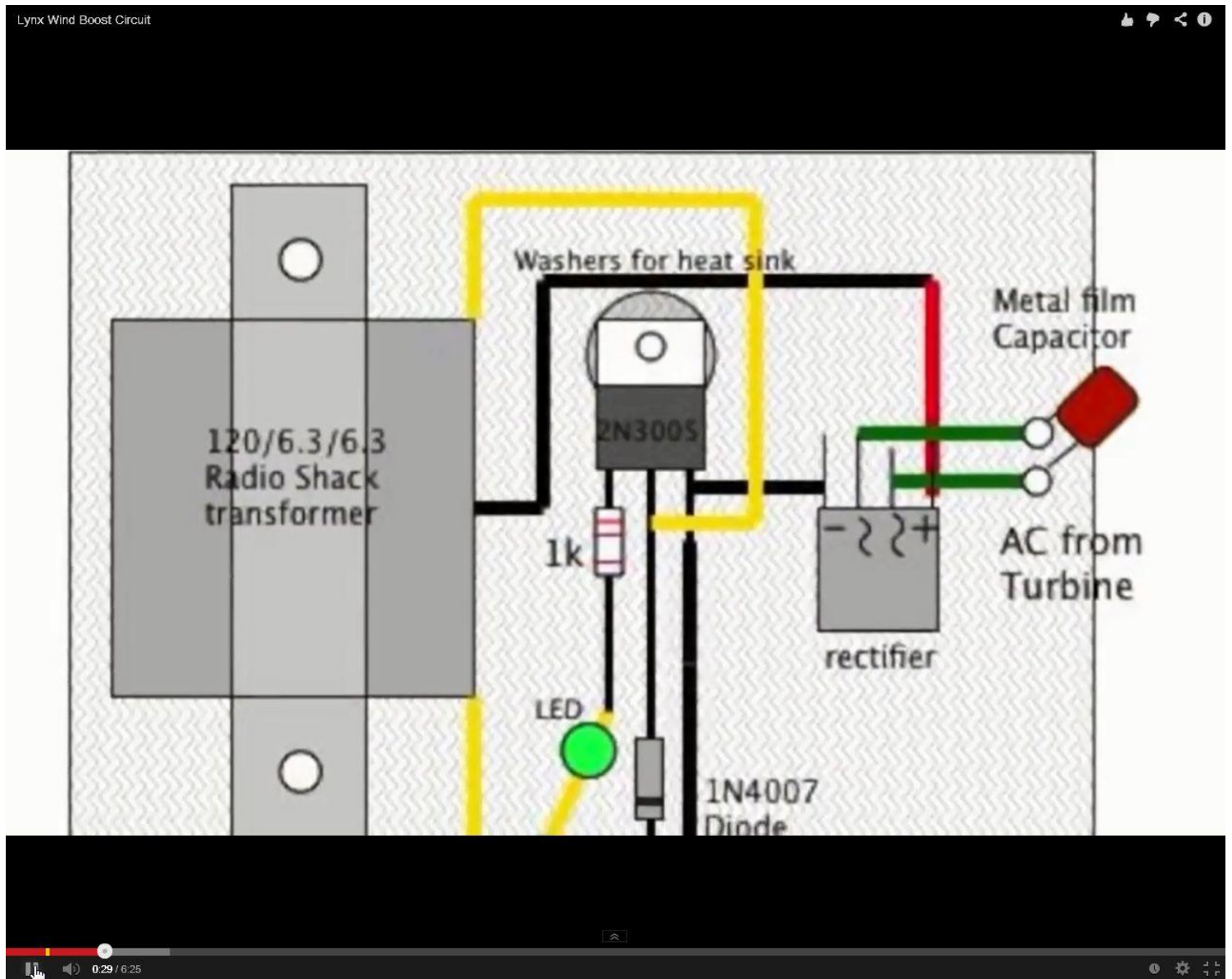

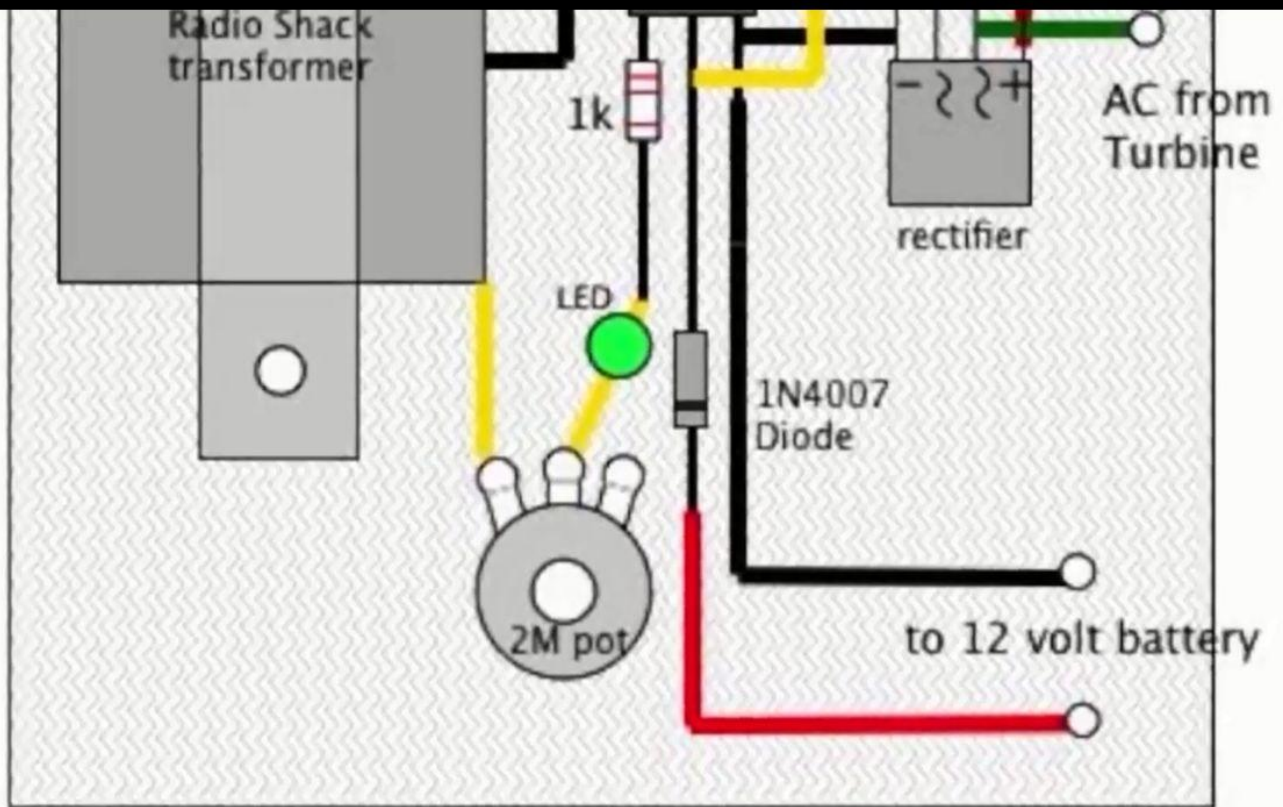

Windows taskbar showing Start button, various application icons (Internet Explorer, Firefox, etc.), system tray with clock and date (11:33 AM 4/14/2014).

Video for above: [https://www.youtube.com/watch?v=cROjBk\\_F8yM](https://www.youtube.com/watch?v=cROjBk_F8yM)

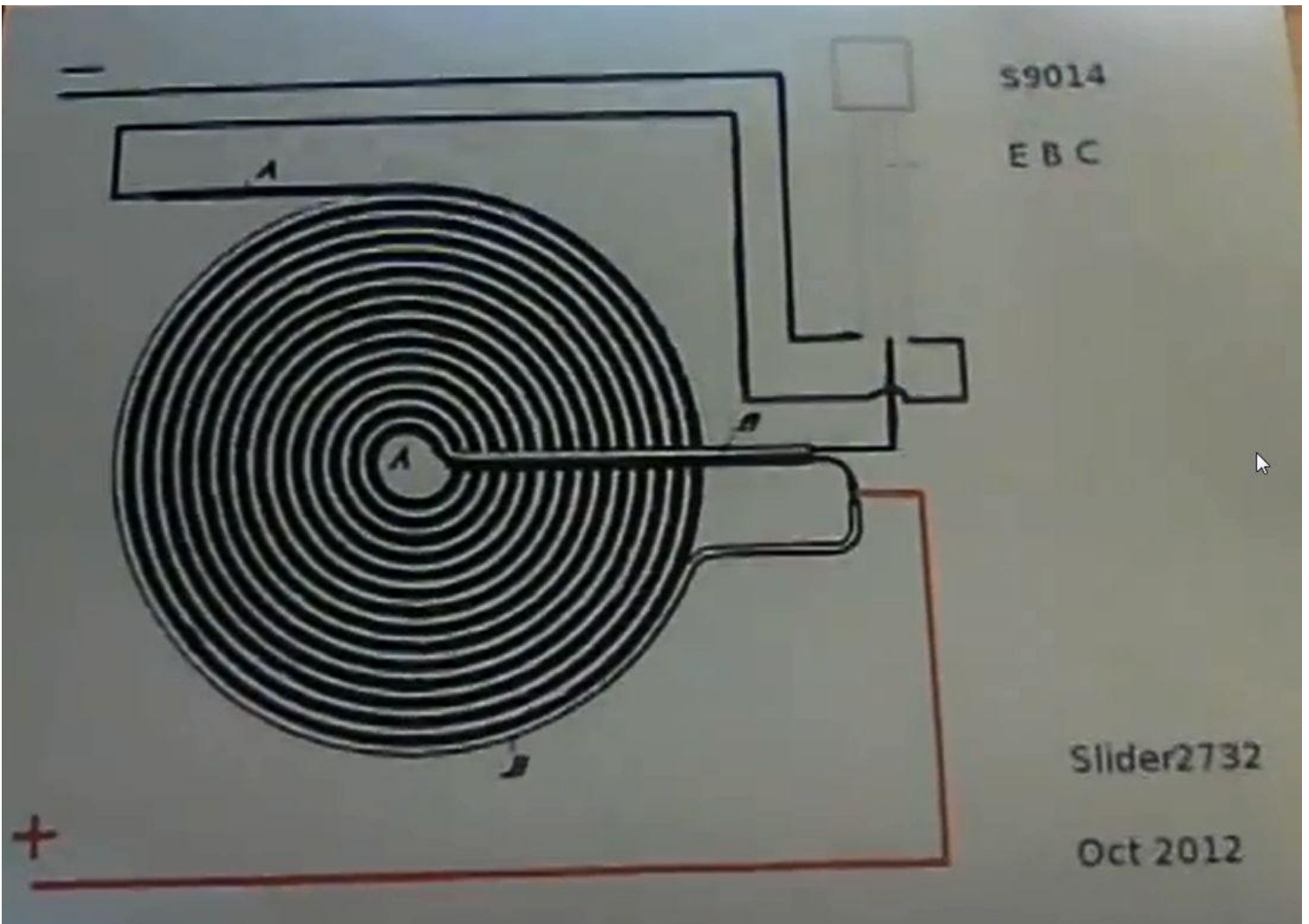
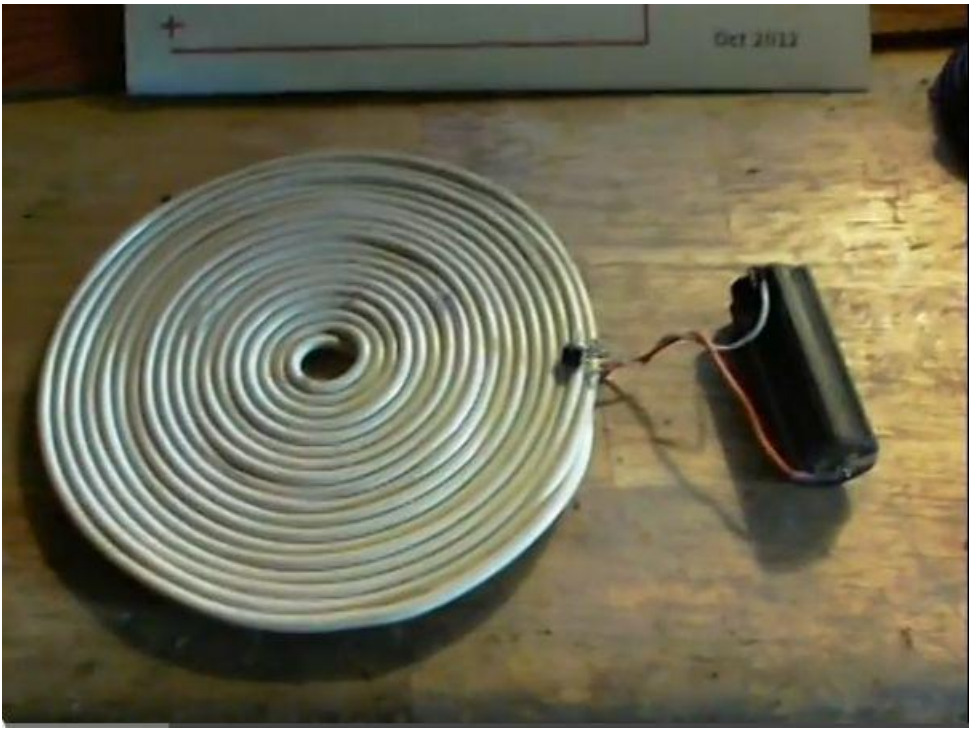

text for above:

A pancake coil and a transistor. 1x AAA battery is being used to power the circuit.

The coil is an old modem lead, with 2 wires running through it. The wires are connected following Nikola Tesla's classic pancake coil method.

All receiving coils are made from similar former computer modem leads.

The first receiving coil shown is a single winding coil, not bifilar, with an LED connected across the start and end of the wire (thanks to YalgorupIT for the middle positioning of the LED idea, he makes his like that and it's a good neat placement).

The second is a pyramid/conical type of bifilar coil, with a blocking oscillator inside and LED out of the top.

The third coil is a bifilar pancake, with a blocking oscillator circuit mounted on the top. This coil shows that the energy can power circuit loads.

The effect of transfer was discovered by accident a couple of weeks ago... RimstarOrg enjoyed a similar video recently for that reason and hopefully he will try this one too.

I was moving some circuits out of the way in the utility room and one pancake coil oscillator was running via a calculator solar cell. As I crossed over the top of that coil, another pancake oscillator flashed ! Intrigued, I set about experimenting with the effect, which is similar to that noted by several people with Lidmotor's 'Penny' circuit interactions.

Reducing the components to just the transistor gave this circuit shown today :)

I'm not sure of the amperage used, but is likely similar to a Joule Thief draw. A 10ohm resistor may well be used to discover the draw as experiments carry on.

No capacitors, no resistor etc, the pancake is filling in for the usual components with its own resistance and capacitance !

If you have a blocking oscillator the pancake coil placed on top will absorb that energy and run an led